

iW BLAST 12



IntelliWhite™ iW Blast 12 is a robust, high-performance controllable white light system for interior/exterior wall washing and grazing applications. iW Blast 12 provides temperature controllable, high-quality white light with fixture-to-fixture color consistency which is well suited for enhancing architectural detail, theatrical stage, and studio lighting. iW Blast 12 provides flexible color temperature and brightness control through Chromacore®, the proven technology that underlies Color Kinetics' existing intelligent solid-state lighting systems. When applied to IntelliWhite products, Chromacore controls channels of warm white and cool white LEDs to produce output of color temperatures within the range of 3000 - 6500 kelvin from within a single fixture. iW Blast 12 allows the adjustment of intensity while providing the option to either maintain constant color temperature or vary the color temperature.

iW Blast 12 is a sealed product designed for both indoor and outdoor installations. The stylish and rugged die-cast aluminum housing meets or exceeds specifications for use in wet and damp locations. iW Blast 12 is available with a soft-focus, tempered glass lens or a clear tempered glass lens. The soft-focus lens produces a soft-edge 24° beam of light, while the clear lens offers an 18° beam angle for extended light projection. The housing is also equipped to affix spread lenses, louvers, and other attachments and is available in either a black or white powder coat finish to match its environment and prevent oxidation. A single 3-wire, 60-foot (18.3 m) cable, which provides both power and data to the light fixture, is rated for outdoor installations.

Designed to quickly aim the fixture without the need of special tools, iW Blast 12 includes an industrial-grade constant torque hinge. Set screws and an Allen wrench are included for installations requiring locked positioning. The versatile base of iW Blast 12 can be mounted to a junction box on a wall, ceiling, or floor. iW Blast 12 includes a separate canopy, liquid-tight cable fitting, and swivel bracket. For a more finished look, mount the canopy to the base and mounting surface. The liquid-tight cable fitting seals the canopy opening. The swivel bracket allows for flexible fixture positioning.

For protection from extreme temperatures, iW Blast 12 has been designed with a temperature monitoring feature. If operating temperatures rise to an unsafe level, a compensation circuit is triggered and iW Blast 12 operation is interrupted causing the lights to turn dim warm. After 30 minutes the lights will auto-cycle and return to full intensity.

iW BLAST 12 SPECIFICATIONS

COLOR RANGE	3000K to 6500K
SOURCE	High intensity power LEDs
BEAM ANGLE	18° clear lens, 24° ground lens
HOUSING	Die Cast Aluminum, black or white powder coat finish
LENSES	Soft-focus tempered glass or clear tempered glass
CONNECTORS	Unified power and data cable
LISTINGS	C-UL US listed, CE certified

COMMUNICATION SPECIFICATIONS

DATA INTERFACE	Color Kinetics iW PDS-150
CONTROL	Color Kinetics line of iW controllers including iW Scene Controller

ELECTRICAL SPECIFICATIONS

POWER REQUIREMENT	24VDC
POWER CONSUMPTION	50W Max. at full output
POWER SUPPLY	iW PDS-150 (ITEM# 509-000001-00)

ENVIRONMENTAL SPECIFICATIONS

TEMPERATURE RANGE	-4°F to 122°F (-20°C to 50°C) based on testing of specific product
PROTECTION RATING	IP66

LED SOURCE LIFE

In traditional lamp sources, lifetime is defined as the point at which 50% of the lamps fail. This is also termed Mean Time Between Failure [MTBF]. LEDs are semiconductor devices and have a much longer MTBF than conventional sources. However, MTBF is not the only consideration in determining useful life. Color Kinetics uses the concept of useful light output for rating source lifetimes. Like traditional sources, LED output degrades over time (lumen depreciation) and this is the metric for SSL lifetime.

LED lumen depreciation is affected by numerous environmental conditions such as ambient temperature, humidity, and ventilation. Lumen depreciation is also affected by means of control, thermal management, current levels, and a host of other electrical design considerations. Color Kinetics systems are expertly engineered to optimize LED life when used under normal operating conditions. Lumen depreciation information is based on LED manufacturers' source life data as well as other third party testing. Low temperatures and controlled effects have a beneficial effect on lumen depreciation. Overall system lifetime could vary substantially based on usage and the environment in which the system is installed.

Temperature and effects will affect lifetime. Color Kinetics rates product lifetime using lumen depreciation to 70% of original light output. When the fixture is running on warm or cool, at room temperature, the LED lifetime is in the range 50,000 – 70,000 hours. This is LED manufacturers' test data. High output is defined as any LED device that is 1/2 watt or above. For more detailed information on source life, please see www.colorkinetics.com/lifetime.

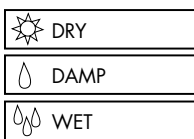

- ITEM# 501-000007-00 (White)
 501-000007-01 (Black)
 501-000007-02 (Aluminum)
 501-000007-03 (White, Clear)
 501-000007-04 (Black, Clear)
 501-000007-05 (Aluminum, Clear)

This product is protected by one or more of the following patents: U.S. Patent Nos. 6,016,038, 6,150,774 and other patents listed at <http://colorkinetics.com/patents/>. Other patents pending.

©2004-2006 Color Kinetics Incorporated. All rights reserved. Chromacore, Chromatic, Color Kinetics, the Color Kinetics logo, ColorBlast, ColorBlaze, ColorBurst, ColorCast, ColorPlay, ColorScape, Direct Light, iColor, iColor Cove, iPlayer, Optibin, Powercore, QuickPlay, Sauce, the Sauce logo, and Smartjuice are registered trademarks and DIMand, EssentialWhite, IntelliWhite, and Light Without Limits are trademarks of Color Kinetics Incorporated.

All other brand or product names are trademarks or registered trademarks of their respective owners.

BR0151 Rev 03

Specifications subject to change without notice. Refer to www.colorkinetics.com for the most recent data sheet versions.

iW BLAST 12 CLEAR LENS

PHOTOMETRIC PERFORMANCE

SOURCE SPECIFICATIONS

Optics:	Clear glass diffuser
Source:	30 LEDs (20 warm white, 10 cool white)
Beam Angle:	18°
Distribution:	Symmetric direct illumination
CCT:	Adjustable 3,000-6,500K
CRI:	78 All, 71 Warm, 83 Cool

ILLUMINANCE DISTRIBUTION

1.5 16.1	2.9 31.2	3.8 40.9	3.3 35.5	2.1 22.6	1.3 14.0	1.0'/0.3m
2.3 24.8	6.9 74.3	11.1 119.5	8.6 92.6	3.9 42.0	1.7 18.3	2.0'/0.6m
3.1 33.4	15.5 166.8	29.3 315.4	22.7 244.3	8.3 89.3	2.4 25.8	3.0'/1.0m
3.0 32.3	17.6 189.4	39.9 429.5	38.6 415.5	16.2 174.4	3.0 32.3	4.0'/1.2m
1.9 20.5	9.1 98.0	26.4 284.2	33.0 355.2	16.5 177.6	2.8 30.1	5.0'/1.5m
1.0 10.8	2.8 30.1	8.9 95.8	12.8 137.8	7.4 79.7	1.7 18.3	6.0'/2.0m
3.0'/1.0m		0'/0m			3.0'/1.0m	

Units: Footcandles (top)/Lux (bottom)
10.8 lux = 1 fc

Location: Bottom of grid, 3'/1m from surface, light at a 45° angle off horizontal

Measured on: All, reflectance model 80/50/20%

ILLUMINANCE

	3' 1m	6' 2m	9' 3m	15' 5m
ALL	345.0 3713.6	86.2 927.9	38.3 412.3	13.8 148.5

Measured in Footcandles (top)/Lux (bottom) on axis
Measured on all, reflectance 0

CANDLE POWER DISTRIBUTION

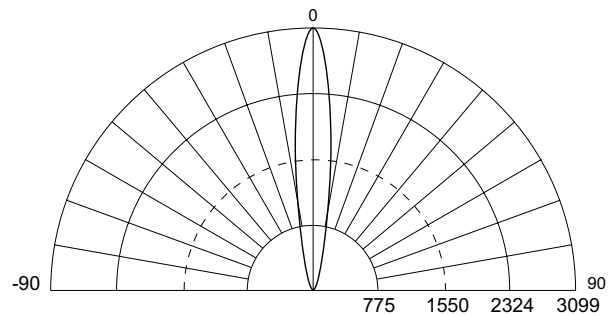

Measured on: All
Beam center: 3099 cd
Thin dashed lined: Indicates 50% of peak

LIGHT OUTPUT

	TOTAL OUTPUT (lumens)	POWER (Watts)	EFFICACY (Lm/w)
ALL	389	48.0	8.1
WARM	235	32.2	7.3
COOL	169	15.8	10.7

Note: Efficacy figures are for a complete tested fixture not simply a lamp source.

CRI

It is common practice in the lighting industry to use color rendering index (CRI) to compare the properties of various light sources. There are known deficiencies and limitations associated with CRI and as a result, it is not always an accurate indicator of good object color appearance. This is especially true for LED-based sources. Until a better method for measuring color rendering in LEDs is accepted, Color Kinetics measures CRI in accordance with the current CIE 13.3-1995 standard using the Ra calculation. The reference illuminants employed are the Planckian locus below 5000K and CIE Daylight reference above 5000K. All measurements for Color Kinetics products are performed by third party laboratories using NIST-traceable instruments.

iW BLAST 12 GROUND LENS

PHOTOMETRIC PERFORMANCE

SOURCE SPECIFICATIONS

Optics:	Soft-focus tempered glass
Source:	30 LEDs (20 warm white, 10 cool white)
Beam Angle:	24°
Distribution:	Symmetric direct illumination
CCT:	Adjustable 3,000-6,500K
CRI:	77 All, 70 Warm, 83 Cool

ILLUMINANCE DISTRIBUTION

2.0 21.5	3.3 35.5	4.1 44.1	3.7 39.8	2.6 28.0	1.7 18.3	1.0'/0.3m
2.8 30.1	6.2 66.7	9.0 96.9	7.8 84.0	4.5 48.4	2.3 24.8	2.0'/0.6m
3.8 40.9	11.3 121.6	18.7 201.3	15.9 171.1	7.8 84.0	3.0 32.3	3.0'/1.0m
3.9 42.0	13.8 148.5	26.3 283.1	24.8 266.9	12.2 131.3	3.8 40.9	4.0'/1.2m
3.0 32.3	9.9 106.6	21.5 231.4	24.0 258.3	13.1 141.0	3.7 39.8	5.0'/1.5m
1.8 19.4	4.5 48.4	10.2 109.8	13.1 141.0	8.0 86.1	2.6 28.0	6.0'/2.0m
3.0'/1.0m	0'/0m				3.0'/1.0m	

Units: Footcandles (top)/Lux (bottom)
10.8 lux = 1 fc

Location: Bottom of grid, 3'/1m from surface, light at a 45° angle off horizontal

Measured on: All, reflectance model 80/50/20%

ILLUMINANCE

	3' 1m	6' 2m	9' 3m	15' 5m
ALL	139.0 1496.2	34.9 375.7	15.5 166.8	5.6 60.3

Measured in Footcandles (top)/Lux (bottom) on axis
Measured on all, reflectance 0

CANDLE POWER DISTRIBUTION

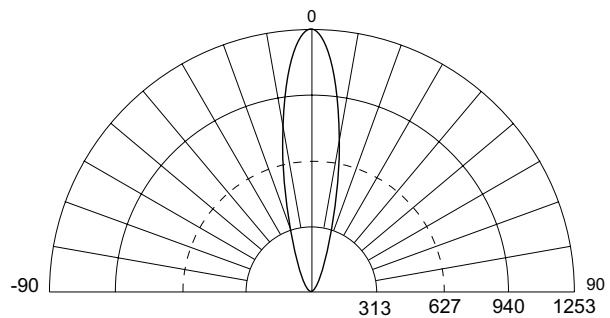

Measured on: All
Beam center: 1253 cd
Thin dashed lined: Indicates 50% of peak

LIGHT OUTPUT

	TOTAL OUTPUT (lumens)	POWER (Watts)	EFFICACY (Lm/w)
ALL	371	48.0	7.7
WARM	233	32.2	7.2
COOL	158	15.8	10.0

Note: Efficacy figures are for a complete tested fixture not simply a lamp source.

CRI

It is common practice in the lighting industry to use color rendering index (CRI) to compare the properties of various light sources. There are known deficiencies and limitations associated with CRI and as a result, it is not always an accurate indicator of good object color appearance. This is especially true for LED-based sources. Until a better method for measuring color rendering in LEDs is accepted, Color Kinetics measures CRI in accordance with the current CIE 13.3-1995 standard using the Ra calculation. The reference illuminants employed are the Planckian locus below 5000K and CIE Daylight reference above 5000K. All measurements for Color Kinetics products are performed by third party laboratories using NIST-traceable instruments.

iW BLAST 12

PHYSICAL DIMENSIONS

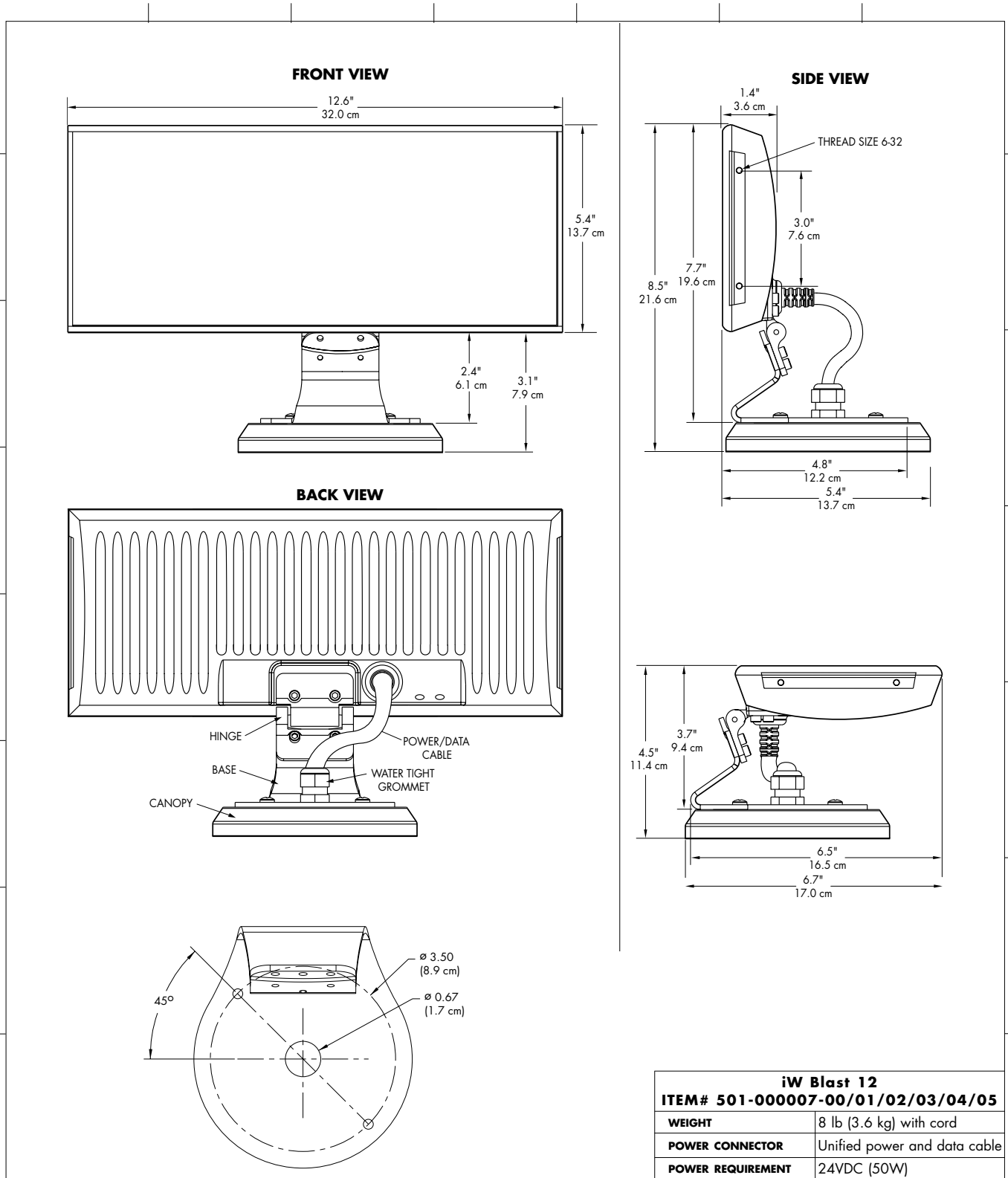

iW BLAST 12

FUNCTIONAL FLOW DIAGRAM

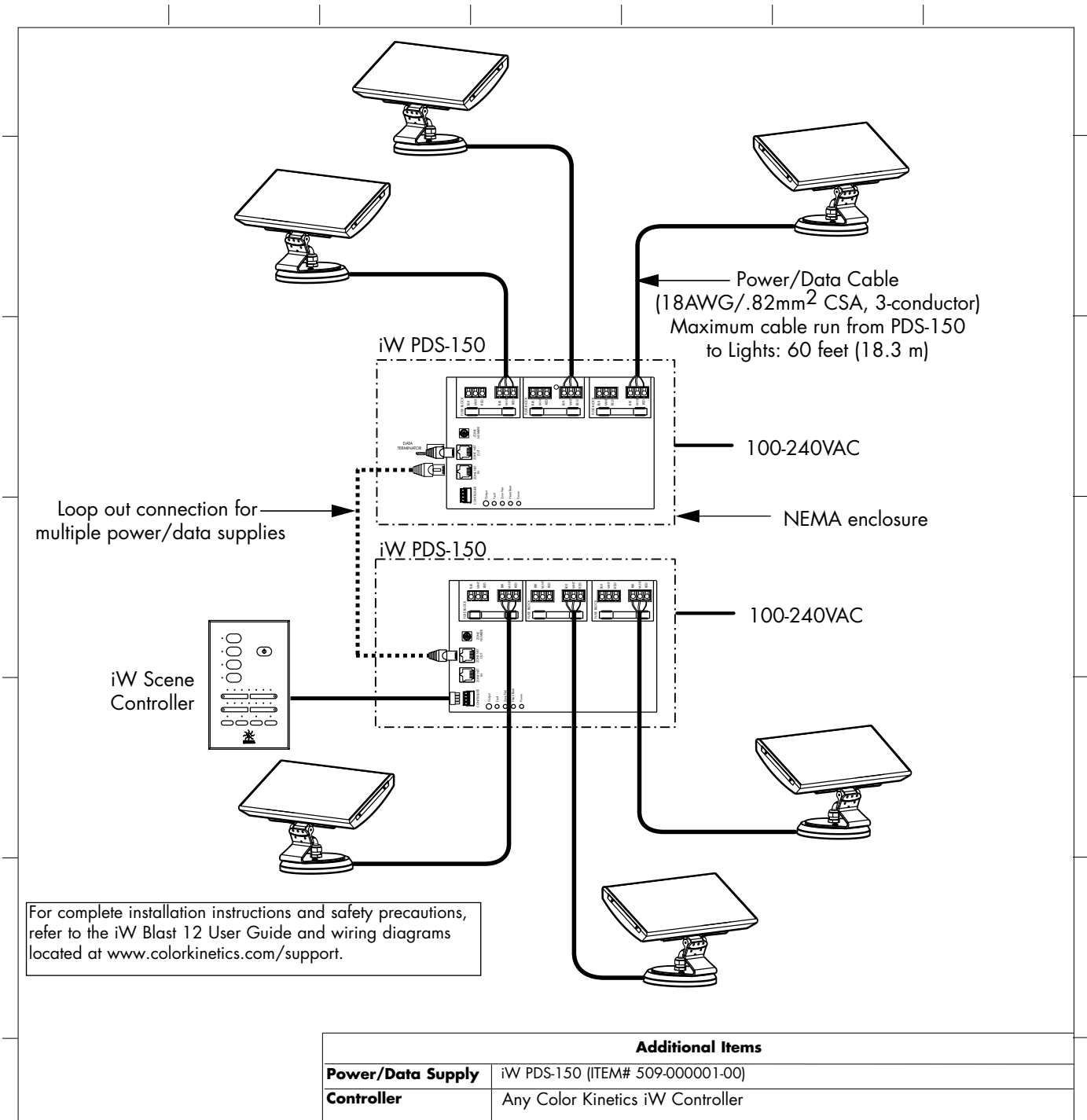

OPTIBIN®

There are inherent variations in the fabrication processes of all semiconductor materials. For LEDs, this variance results in differences in the color and intensity of light output as well as electrical characteristics. Due to these differences, LED manufacturers sort production into "bins," but insuring the availability of a single bin is very difficult. To minimize this issue and achieve optimal color consistency in its products, Color Kinetics has developed and uses a proprietary technology called Optibin. Optibin is an advanced production binning optimization process that minimizes the effects of LED variance for the best possible output uniformity in the final product. Color Kinetics Optibin technology gives you the most consistent control of color and intensity from product to product.