

DLE C-301

POWERED BY CHROMACORE®

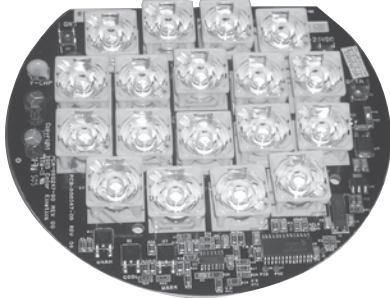

Color Kinetics® DLE C-301 solid-state digital light engine is a complete, networkable illumination module intended for integration into a wide variety of OEM white lighting products and custom installations. On-board intelligence drives the light emitting diodes (LEDs), stores configuration data, and monitors the temperature of the light engine. With simple control and power input, DLE C-301 delivers a broad range of color temperature control. Separate control channels enable color temperature control from 3000K to 6500K. Metal-core printed circuit board (PCB) construction ensures highly efficient heat dissipation and thermal performance.

DLE C-301 accepts commands using the DMX512 packet format. Three sequential channels are used: two for warm and one for cool. These three 8-bit channels provide full 24-bit control of the emitted color. Thus, DLE C-301 can be instructed to produce color temperatures from 3000K to 6500K.

DLE C-301 uses 18 high power emitters driven by precision current sources that are tolerant of wide variations in temperature and supply voltage, and whose intensity is controlled by an advanced pulse width modulation (PWM) algorithm. DLE C-301 uses 14-bit PWM natively.

DLE C-301 has an on-board processor equipped with non-volatile memory that stores configuration and performance data. Each DLE module is uniquely and permanently serialized at the time of manufacture, and this serial number can be used to identify the module in an installation or network, even if that installation contains other Color Kinetics lights or fixtures from other OEMs that use Color Kinetics DLEs.

DLE C-301 SPECIFICATIONS

COLOR RANGE	3000K to 6500K
SOURCE	High intensity power LEDs
WEIGHT	5.25 oz (148.8 g)

COMMUNICATION SPECIFICATIONS

DATA INTERFACE	CKDMX
CONTROL	Color Kinetics full line of controllers or DMX512 (RS485) when using a Color Kinetics power/data supply

ELECTRICAL SPECIFICATIONS

POWER REQUIREMENT	24VDC Regulated, +/- 0.5V
POWER CONSUMPTION	25W

ENVIRONMENTAL SPECIFICATIONS

MAXIMUM TEMPERATURE	Housing dependent. Design should provide adequate heat transfer such that no individual component exceeds maximum levels specified in the Thermal Management Section of the Digital Light Engine Integration Guide. Over temperature protection circuit operates when component temperature exceeds acceptable limits.
MINIMUM TEMPERATURE	-20°C
ENVIRONMENT	Non-corrosive
HUMIDITY	0-95% non-condensing

CHROMACORE®
BY COLOR KINETICS

OPTIBIN®
BY COLOR KINETICS

DLE C-301 ITEM# 118-000071-00 (18° Beam Angle)
DLE C-301 ITEM# 118-000071-01 (22° Beam Angle)

This product is protected by one or more of the following patents: U.S. Patent Nos. 6,016,038, 6,150,774 and other patents listed at <http://colorkinetics.com/patents/>. Other patents pending.

©2005-2006 Color Kinetics Incorporated. All rights reserved. Chromacore, Chromasic, Color Kinetics, the Color Kinetics logo, ColorBlast, ColorBlaze, ColorBurst, ColorCast, ColorPlay, ColorScape, Direct Light, iColor, iColor Cove, iPlayer, Optibin, Powercore, QuickPlay, Sauce, the Sauce logo, and SmartJuice are registered trademarks and DIMand, EssentialWhite, IntelliWhite, and Light Without Limits are trademarks of Color Kinetics Incorporated.

All other brand or product names are trademarks or registered trademarks of their respective owners.

BRO173 Rev 01

Specifications subject to change without notice. Refer to www.colorkinetics.com for the most recent data sheet versions.

LED SOURCE LIFE

In traditional lamp sources, lifetime is defined as the point at which 50% of the lamps fail. This is also termed Mean Time Between Failure [MTBF]. LEDs are semiconductor devices and have a much longer MTBF than conventional sources. However, MTBF is not the only consideration in determining useful life. Color Kinetics uses the concept of useful light output for rating source lifetimes. Like traditional sources, LED output degrades over time (lumen depreciation) and this is the metric for SSL lifetime.

LED lumen depreciation is affected by numerous environmental conditions such as ambient temperature, humidity, and ventilation. Lumen depreciation is also affected by means of control, thermal management, current levels, and a host of other electrical design considerations. Color Kinetics systems are expertly engineered to optimize LED life when used under normal operating conditions. Lumen depreciation information is based on LED manufacturers' source life data as well as other third party testing. Low temperatures and controlled effects have a beneficial effect on lumen depreciation. Overall system lifetime could vary substantially based on usage and the environment in which the system is installed.

Temperature and effects will affect lifetime. Color Kinetics rates product lifetime using lumen depreciation to 70% of original light output. When the fixture is running on warm or cool, at room temperature, the LED lifetime is in the range 50,000 – 70,000 hours. This is LED manufacturers' test data. High output is defined as any LED device that is 1/2 watt or above. For more detailed information on source life, please see www.colorkinetics.com/lifetime.

OPTIBIN®

There are inherent variations in the fabrication processes of all semiconductor materials. For LEDs, this variance results in differences in the color and intensity of light output as well as electrical characteristics. Due to these differences, LED manufacturers sort production into "bins," but insuring the availability of a single bin is very difficult. To minimize this issue and achieve optimal color consistency in its products, Color Kinetics has developed and uses a proprietary technology called Optibin. Optibin is an advanced production binning optimization process that minimizes the effects of LED variance for the best possible output uniformity in the final product. Color Kinetics Optibin technology gives you the most consistent control of color and intensity from product to product.

DLE C-301 18° BEAM ANGLE

PHOTOMETRIC PERFORMANCE

Photometric data is based on test results from an independent testing lab.

SOURCE SPECIFICATIONS

Source: 18 LEDs (12 Warm, 6 Cool)
 Beam Angle: 18 degrees
 Distribution: Symmetric direct illumination
 CCT: Adjustable 3,000K-6,500K
 CRI: 79 All, 72 Warm, 81 Cool
 (Values based on equivalent clear lens product.)

ILLUMINANCE DISTRIBUTION

0.5 5.4	0.9 9.7	1.3 14.0	1.0 10.8	0.6 6.5	0.4 4.3	1.0'/0.3m
0.7 7.5	3.2 34.4	5.8 62.4	3.9 42.0	1.2 12.9	0.5 5.4	2.0'/0.6m
0.9 9.7	10.3 110.9	21.5 231.4	15.1 162.5	3.7 39.8	0.7 7.5	3.0'/1.0m
0.8 8.6	10.6 114.1	28.7 308.9	28.7 308.9	10.7 115.2	0.9 9.7	4.0'/1.2m
0.6 6.5	3.4 36.6	14.9 160.4	21.8 234.7	10.5 113.0	0.9 9.7	5.0'/1.5m
0.5 5.4	0.8 8.6	3.3 35.5	5.5 59.2	3.2 34.4	0.7 7.5	6.0'/2.0m
3.0'/1.0m		0'/0m				3.0'/1.0m

Units: Footcandles (top)/Lux (bottom)
 10.8 lux = 1 fc
 Measured on: All, reflectance model 80/50/20%
 Distance from surface: Bottom of grid, 3' (1 m) from surface,
 45° angle off horizontal

CANDLE POWER DISTRIBUTION

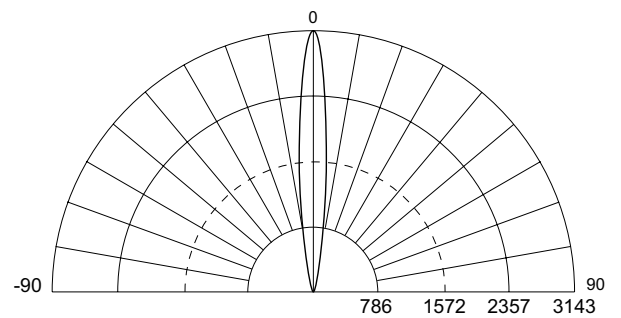

Measured on: Add
 Beam center: 3143 cd
 Thin dashed line: Indicates 50% of peak

ILLUMINANCE

COLOR	3' 1m	6' 2m	9' 3m	15' 5m
ALL	456.0 4908.4	99.3 1068.9	42.2 454.2	14.7 158.2

Measured in Footcandles (top)/Lux (bottom) on axis.
 Measured on: All, reflectance 0.

LIGHT OUTPUT

COLOR	TOTAL OUTPUT (lumens)	POWER (Watt)	EFFICACY (Lm/W)
ALL	223	24.5	9.1
WARM	147	16.6	8.9
COOL	109	8.4	13.0

CRI

It is common practice in the lighting industry to use color rendering index (CRI) to compare the properties of various light sources. There are known deficiencies and limitations associated with CRI and as a result, it is not always an accurate indicator of good object color appearance. This is especially true for LED-based sources. Until a better method for measuring color rendering in LEDs is accepted, Color Kinetics measures CRI in accordance with the current CIE 13.3-1995 standard using the Ra calculation. The reference illuminants employed are the Planckian locus below 5000K and CIE Daylight reference above 5000K. All measurements for Color Kinetics products are performed by third party laboratories using NIST-traceable instruments.

DLE C-301 22° BEAM ANGLE

PHOTOMETRIC PERFORMANCE

Photometric data is based on test results from an independent testing lab.

SOURCE SPECIFICATIONS

Source: 18 LEDs (12 Warm, 6 Cool)
 Beam Angle: 22 degrees
 Distribution: Symmetric direct illumination
 CCT: Adjustable 3,000K-6,500K
 CRI: 79 All, 72 Warm, 81 Cool
 (Values based on equivalent clear lens product.)

ILLUMINANCE DISTRIBUTION

0.7 7.5	1.4 15.1	1.9 20.5	1.6 17.2	1.0 10.8	0.6 6.5	1.0'/0.3m
1.1 11.8	3.8 40.9	6.4 68.9	4.7 50.6	1.9 20.5	0.8 8.6	2.0'/0.6m
1.5 16.1	9.3 100.1	18.1 194.8	13.5 145.3	4.4 47.4	1.1 11.8	3.0'/1.0m
1.3 14.0	10.0 107.6	24.2 260.5	23.3 250.8	9.2 99.0	1.4 15.1	4.0'/1.2m
0.9 9.7	4.4 47.4	14.6 157.2	19.0 204.5	9.1 98.0	1.3 14.0	5.0'/1.5m
0.6 6.5	1.3 14.0	4.3 46.3	6.5 70.0	3.7 39.8	0.9 9.7	6.0'/2.0m
3.0'/1.0m	0'/0m	0'/0m	0'/0m	0'/0m	3.0'/1.0m	

Units: Footcandles (top)/Lux (bottom)
 10.8 lux = 1 fc
 Measured on: All, reflectance model 50%
 Distance from surface: 1' (0.3 m) from surface, perpendicular to surface

CANDLE POWER DISTRIBUTION

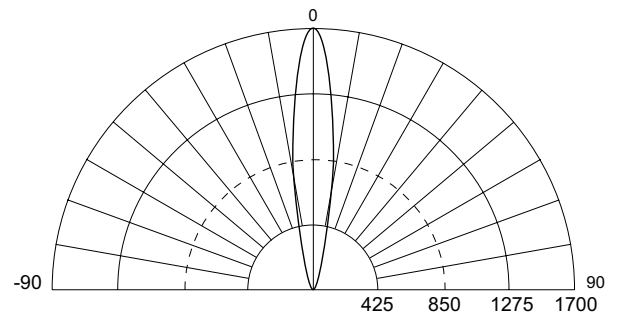

Measured on: All
 Beam center: 1700 cd
 Thin dashed lined: Indicates 50% of peak

ILLUMINANCE

COLOR	3' 1m	6' 2m	9' 3m	15' 5m
ALL	246.0 2647.9	53.7 578.0	22.9 246.5	7.9 85.0

Measured in Footcandles (top)/Lux (bottom) on axis.
 Measured on: All, reflectance 0.

LIGHT OUTPUT

COLOR	TOTAL OUTPUT (lumens)	POWER (Watt)	EFFICACY (Lm/W)
ALL	223	24.5	9.1
WARM	151	16.6	9.1
COOL	102	8.4	12.1

CRI

It is common practice in the lighting industry to use color rendering index (CRI) to compare the properties of various light sources. There are known deficiencies and limitations associated with CRI and as a result, it is not always an accurate indicator of good object color appearance. This is especially true for LED-based sources. Until a better method for measuring color rendering in LEDs is accepted, Color Kinetics measures CRI in accordance with the current CIE 13.3-1995 standard using the Ra calculation. The reference illuminants employed are the Planckian locus below 5000K and CIE Daylight reference above 5000K. All measurements for Color Kinetics products are performed by third party laboratories using NIST-traceable instruments.

DLE C-301

PHYSICAL DIMENSIONS AND THERMAL MEASUREMENT

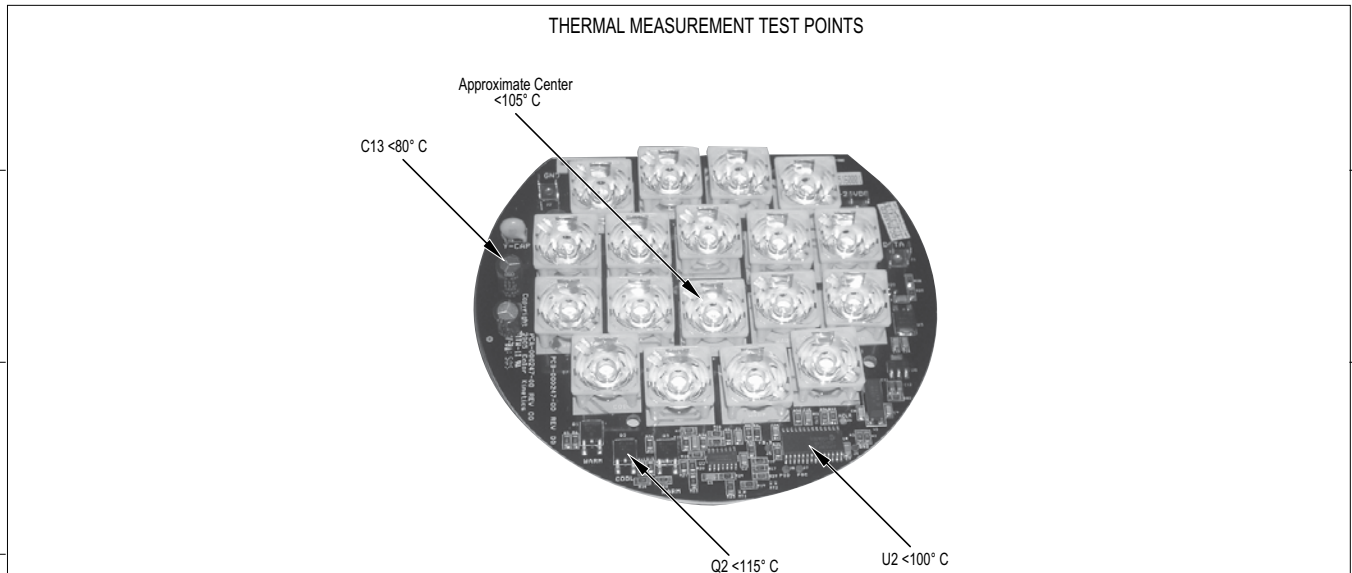
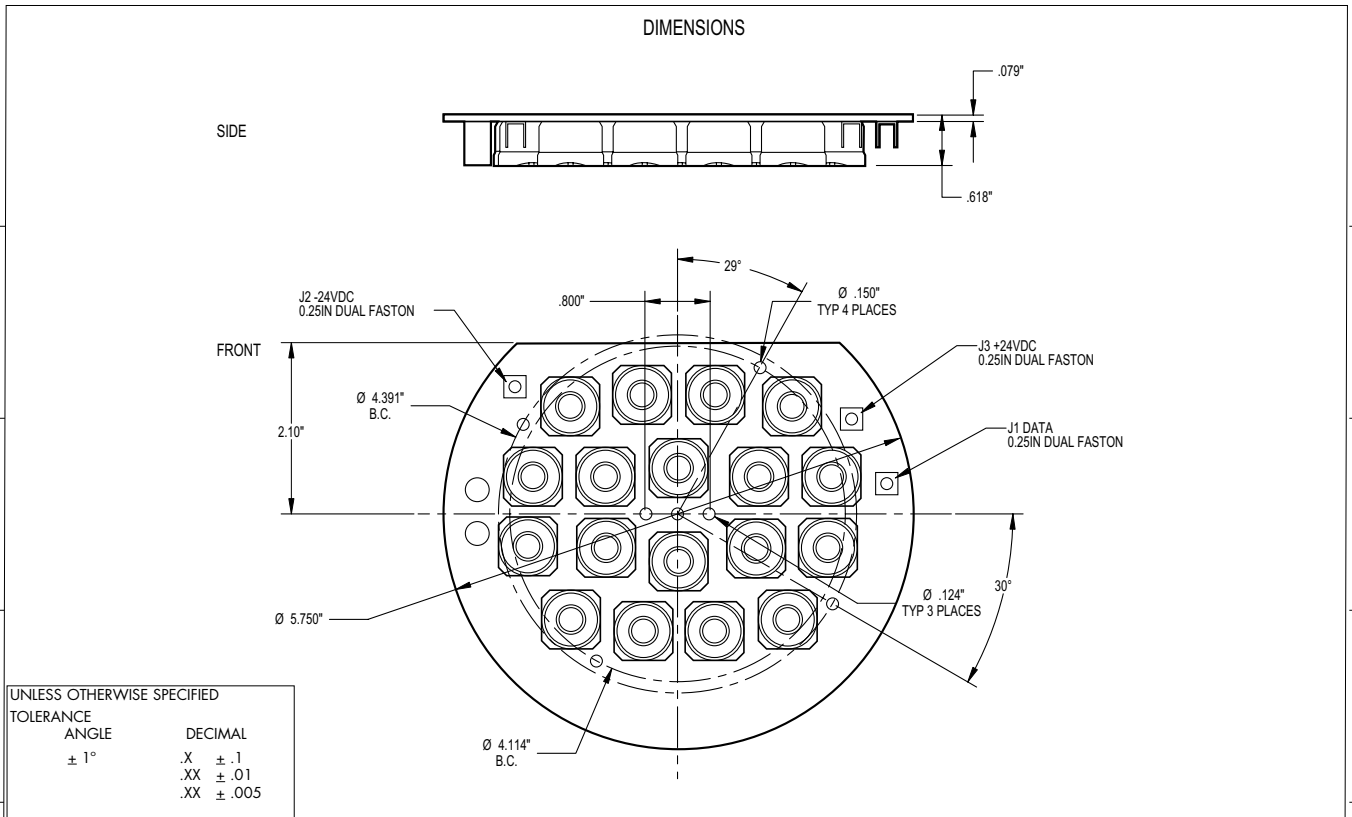

Thermal Measurement

DLE C-301 generates a maximum amount of heat when all LEDs are on full power. Set the board so all LEDs are at full power and allow everything to warm up and stabilize before testing. Thermal tests must be performed at the system's highest rated operating temperature. For elevated ambient temperatures, test the system in an environmental chamber or similar test apparatus that can maintain the desired ambient temperature for the duration of the test.

Using a thermocouple, measure the DLE C-301 at the locations indicated above and ensure they are below the maximum temperature.

Note: Refer to the Integration Guide for complete integration instructions and warnings.

DLE C-301

FUNCTIONAL FLOW DIAGRAM

Typical Installation Using Color Kinetics PDM-301 Power/Data Module
Single DLE: 25W Max Power Output

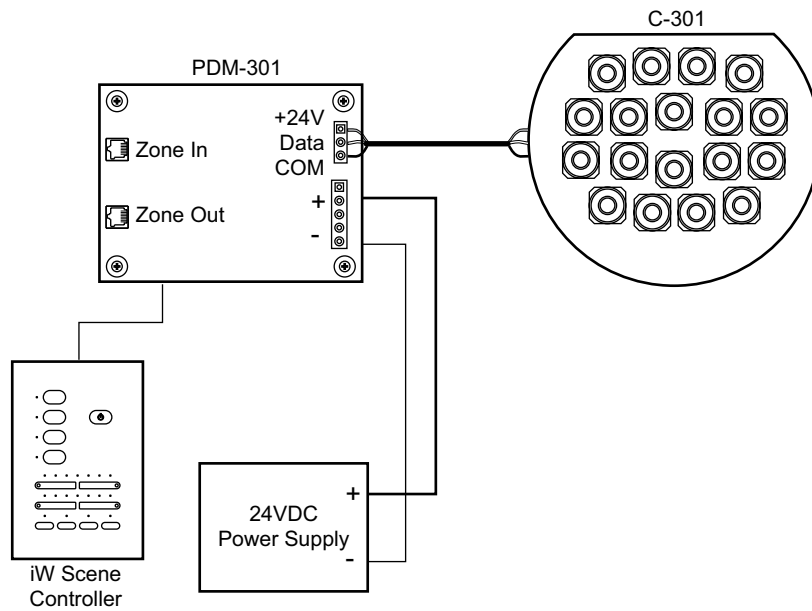

Typical installation using Color Kinetics PDM-301 Power/Data Module
Multiple DLEs:
175ft max length from PDM to last DLE
1.5V max drop at last DLE under full load

