

DLE C-102

POWERED BY CHROMACORE®

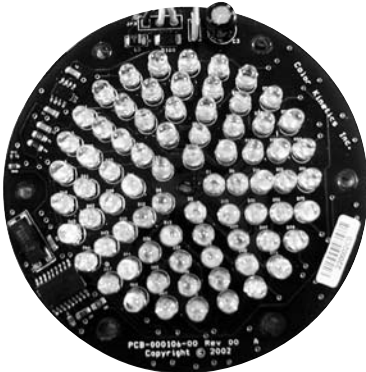

Color Kinetics® DLE C-102 digital light engine is a complete, networkable illumination module intended for integration into a wide variety of OEM lighting products and custom installations. On-board intelligence drives the light emitting diodes (LEDs), stores configuration data, and monitors the temperature of the sub-system. With simple control and power input, DLE C-102 delivers a broad range of color control. Separate red, green, and blue (RGB) control channels enable smooth color mixing across a generous gamut.

DLE C-102 accepts commands using the DMX512 packet format. Three sequential channels are used: one for red, one for green, and one for blue. These three 8-bit channels provide full 24-bit control of the emitted color. Thus, DLE C-102 can be instructed to produce 16 million different colors. Color changes are virtually instantaneous.

DLE C-102 uses 75 5 mm LEDs driven by precision current sources that are tolerant of wide variations in temperature and supply voltage, and whose intensity is controlled by an advanced pulse width modulation (PWM) algorithm. DLE C-102 uses 14-bit PWM natively. The over 16,000 intensities available on each channel are non-linearly mapped to incoming 8-bit DMX data, to better match the human eye's perception of brightness.

DLE C-102's on-board processor has non-volatile memory that stores configuration and performance data. Each DLE module is uniquely and permanently serialized at the time of manufacture, and this serial number can be used to identify the module in an installation or network, even if that installation contains other Color Kinetics lights or fixtures from other OEMs that use Color Kinetics DLEs.

DLE C-102 SPECIFICATIONS

COLOR RANGE 16.7 million (24-bit) additive red, green, and blue colors; continuously variable intensity output range

SOURCE High brightness, 5 mm, colored light emitting diodes (LEDs)

COMMUNICATION SPECIFICATIONS

DATA INTERFACE CKDMX

CONTROL Color Kinetics full line of controllers or DMX512 (RS485) when using Color Kinetics power/data supply

ELECTRICAL SPECIFICATIONS

POWER REQUIREMENT 24VDC Regulated, +/- 0.5V

POWER CONSUMPTION 13.2W Max. at full intensity (full RGB), 40 mA (min.)/0.55 A (max.)

ENVIRONMENTAL SPECIFICATIONS

MAXIMUM TEMPERATURE Housing dependent. Design should provide adequate heat transfer such that no individual component exceeds maximum levels specified in the Thermal Measurement section of this document. Over temperature protection circuit operates when component temperature exceeds acceptable limits.

MINIMUM TEMPERATURE -20°C

ENVIRONMENT Non-corrosive

HUMIDITY 0-95% non-condensing

LED SOURCE LIFE

In traditional lamp sources, lifetime is defined as the point at which 50% of the lamps fail. This is also termed Mean Time Between Failure [MTBF]. LEDs are semiconductor devices and have a much longer MTBF than conventional sources. However, MTBF is not the only consideration in determining useful life. Color Kinetics uses the concept of useful light output for rating source lifetimes. Like traditional sources, LED output degrades over time (lumen depreciation) and this is the metric for SSL lifetime.

LED lumen depreciation is affected by numerous environmental conditions such as ambient temperature, humidity, and ventilation. Lumen depreciation is also affected by means of control, thermal management, current levels, and a host of other electrical design considerations. Color Kinetics systems are expertly engineered to optimize LED life when used under normal operating conditions. Lumen depreciation information is based on LED manufacturers' source life data as well as other third party testing. Low temperatures and controlled effects have a beneficial effect on lumen depreciation. Overall system lifetime could vary substantially based on usage and the environment in which the system is installed.

Temperature and effects will affect lifetime. Color Kinetics rates product lifetime using lumen depreciation to 50% of original light output. When the fixture is running at room temperature using a color wash effect, the range of lifetime is in the range of 30,000-50,000 hours. This is LED manufacturers' test data. For more detailed information on source life, please see www.colorkinetics.com/lifetime.

CHROMACORE®
BY COLOR KINETICS

OPTIBIN®
BY COLOR KINETICS

DLE C-102 ITEM# 118-000019-00

This product is protected by one or more of the following patents:
U.S. Patent Nos. 6,016,038, 6,150,774 and other patents listed at
<http://colorkinetics.com/patents/>. Other patents pending.

©2003-2006 Color Kinetics Incorporated. All rights reserved.
Chromacore, Chromasic, Color Kinetics, the Color Kinetics logo, ColorBlast, ColorBlaze, ColorBurst, ColorCast, ColorPlay, ColorScape, Direct Light, iColor, iColor Cove, iPlayer, Optibin, Powercore, QuickPlay, Sauce, the Sauce logo, and Smartjuice are registered trademarks and DIMand, EssentialWhite, IntelliWhite, and Light Without Limits are trademarks of Color Kinetics Incorporated.

All other brand or product names are trademarks or registered trademarks of their respective owners.

BRO120 Rev 03

Specifications subject to change without notice. Refer to www.colorkinetics.com for the most recent data sheet versions.

DLE C-102

PHOTOMETRIC PERFORMANCE

The photometric data below is based on the following constraints: DLE C-102 is mounted into a 4-inch, round fixture with tempered soft focus glass diffuser. Refer to the ColorBurst® 4 datasheet for example.

Photometric data is based on test results from an independent testing lab.

SOURCE SPECIFICATIONS

Optics:	Tempered soft focus glass diffuser
Source:	755 mm LEDs (25 Red, 25 Green, 25 Blue)
Beam Angle:	33° (at 50% of peak illuminance)
Distribution:	Symmetric direct illumination
CCT:	Adjustable 1,000K-10,000K
CRI:	Not measurable (CIE 13.3-1995)

ILLUMINANCE DISTRIBUTION

3.0'/1.0m					
1.4	2.8	4.4	4.4	2.8	1.4
15.1	30.1	47.4	47.4	30.1	15.1
2.0	5.2	9.6	9.6	5.2	2.0
21.5	56.0	103.3	103.3	56.0	21.5
2.5	8.5	19.7	19.7	8.5	2.5
26.9	91.5	212.1	212.1	91.5	26.9
1.5'/0.5m					
2.5	9.9	30.4	30.4	9.9	2.5
26.9	106.6	327.2	327.2	106.6	26.9
0.7	1.9	21.1	21.1	1.9	0.7
7.5	20.5	227.1	227.1	20.5	7.5
1.1	2.9	6.6	6.6	2.9	1.1
11.8	31.2	71.0	71.0	31.2	11.8
0.0'/0.0m					
1.5'/0.5m		0'/0m		1.5'/0.5m	

Units: Footcandles/Lux
 Measured on: White
 Distance from surface: 1.5'/0.5m (from bottom of grid with light at a 45° angle)
 Multipliers: 0.31 Red, 0.51 Green, 0.26 Blue

ILLUMINANCE

COLOR	3'	6'	9'	15'
	1m	2m	3m	5m
WHITE	20.8 223.7	5.2 55.9	2.3 24.9	0.8 8.9
RED	6.4 69.3	1.6 17.3	0.7 7.7	0.3 2.8
GREEN	10.6 114.1	2.6 28.5	1.2 12.7	0.4 4.6
BLUE	5.4 58.1	1.4 14.5	0.6 6.5	0.2 2.3

Measured in Footcandles/Lux on axis.

OPTIBIN®

There are inherent variations in the fabrication processes of all semiconductor materials. For LEDs, this variance results in differences in the color and intensity of light output as well as electrical characteristics. Due to these differences, LED manufacturers sort production into "bins," but insuring the availability of a single bin is very difficult. To minimize this issue and achieve optimal color consistency in its products, Color Kinetics has developed and uses a proprietary technology called Optibin. Optibin is an advanced production binning optimization process that minimizes the effects of LED variance for the best possible output uniformity in the final product. Color Kinetics Optibin technology gives the most consistent control of color and intensity from product to product.

GAMUT

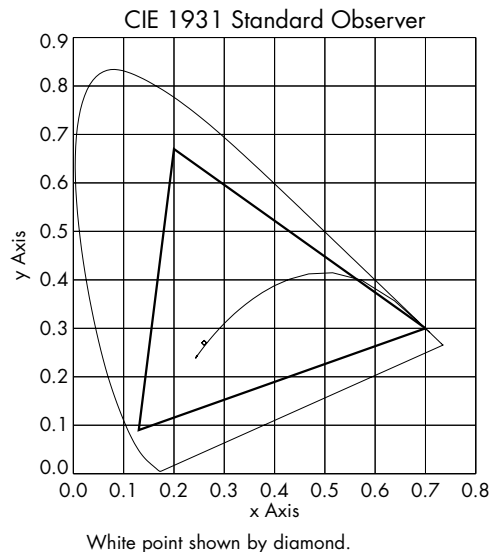

CANDLE POWER DISTRIBUTION

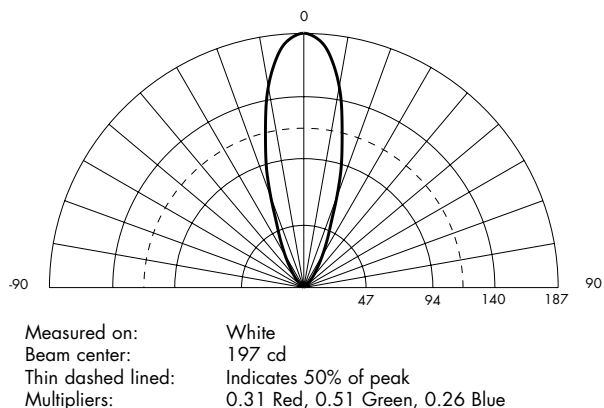

LIGHT OUTPUT

COLOR	WAVE LENGTH (nm)	TOTAL OUTPUT (LUMENS)	POWER (WATTS)	EFFICACY (lm/w)
WHITE	NA	89	10.2	8.72
RED	620.5 - 631	27.6	3.4	8.1
GREEN	520 - 535	45.4	3.4	13.4
BLUE	460 - 480	23.1	3.4	6.8

DLE C-102

PHYSICAL DIMENSIONS AND THERMAL MEASUREMENT

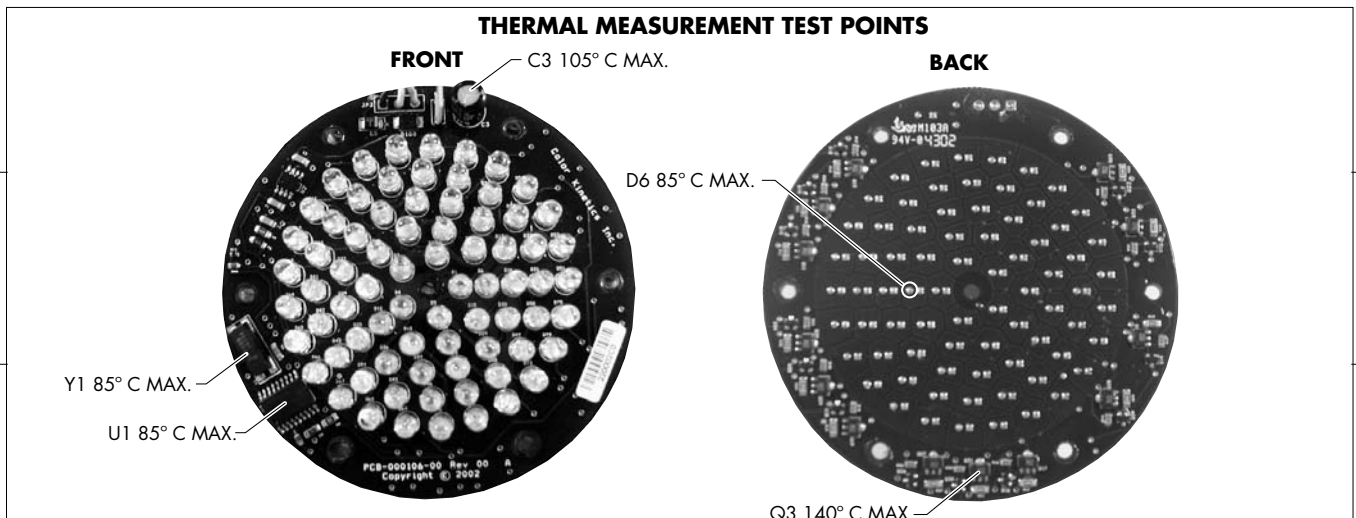
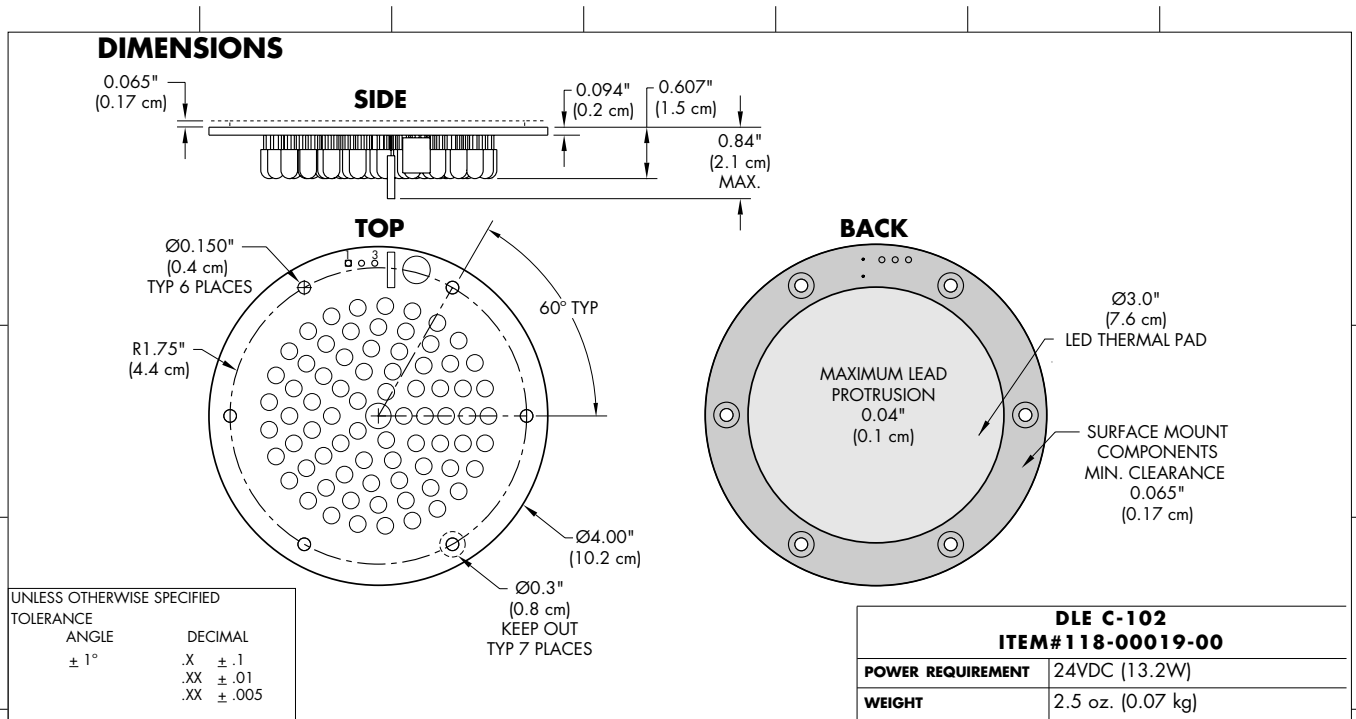

Thermal Measurement

DLE C-102 generates a maximum amount of heat when set to white (full red, green, and blue). Set the board to full white and allow everything to warm up and stabilize before testing. Thermal tests must be performed at the system's highest rated operating temperature. For elevated ambient temperatures, test the system in an environmental chamber or similar test apparatus that can maintain the desired ambient temperature for the duration of the test.

Using a thermocouple, measure the locations indicated above on the DLE C-102 and ensure they are below the maximum temperature.

- FRONT:**
- U1 (microprocessor): 85° C Max.
 - Y1 (crystal): 85° C Max.
 - C3 (capacitor, top): 105° C Max.
- BACK:**
- D6 (round cathode solder pad): 85° C Max.
 - Q3 (transistor metal tab): 140° C Max.

Note: Refer to the Integration Guide for complete instructions and warnings.

DLE C-102

FUNCTIONAL FLOW DIAGRAM

