



COLORCAST 14 CONDUIT

POWERED BY CHROMACORE®



Color Kinetics® ColorCast™ 14 Conduit is a robust, conduit ready, indoor/outdoor linear color changing fixture ideal for high output wall washing and large alcove and archway lighting. ColorCast 14 Conduit offers a solution for installations that require conduit, custom spacing between fixtures, or plenum rating. Like ColorCast 14, it delivers a uniform color wash up to 15 feet (4.6m) while maintaining a lighting ratio of 3:1 or 8:1 depending on the distance from, and type of, surface. When used for large alcove lighting, the continuous end-to-end mounting offers uniform lighting from a short distance above the fixture.

Designed to meet the rugged requirements of outdoor applications, ColorCast 14 Conduit meets specifications for wet locations. The two piece assembly includes a base (sold separately) with four 3/4" NPT threaded conduit holes and four mounting tabs. All electrical connections are made within the base. ColorCast 14 Conduit is extremely versatile and easily adaptable for even the most challenging mounting environments.

ColorCast 14 incorporates ColorCast 14 Conduit incorporates patent-pending Powercore™ digital power processing technology to drive LED systems, integrating power and data management directly into the fixture and eliminating the need for an external power supply. Powercore surpasses traditional power supply technology by streamlining multiple conversion and regulation stages into a single, flexible, microprocessor-controlled power stage that controls power output to LED systems directly from line voltage and significantly increases overall system efficiency. Built-in active power factor correction (PFC) yields higher system efficiencies and minimizes stress on building wiring making the installation and system more cost effective.

ColorCast 14 Conduit receives data via Color Kinetics Data Enabler—a data formatting device that accepts DMX or Color Kinetics Light System Manager (LSM) Ethernet protocols. Each Data Enabler can support up to 70 ColorCast 14 Conduit units, depending on the installation parameters. ColorCast 14 Conduit can be controlled by Color Kinetics' line of controllers, including Color Kinetics Light System Manager, or a third-party DMX controller.

COLORCAST 14 SPECIFICATIONS

COLOR RANGE	16.7 million (24bit) additive RGB colors; continuously variable intensity
SOURCE	High intensity, surface mount, power LEDs
HOUSING	Die cast aluminum, powder coated. Fixture: 13.5" x 3.6" x 1.4" (34.3 cm) x (9.1 cm) x (3.6 cm) Base: 8.9" x 1.9" x 2" (22.6 cm) x (4.8 cm) x (5 cm)
CONNECTORS	Wire nuts
LISTINGS	C-UL US listed, CE certified (Pending)

COMMUNICATION SPECIFICATIONS

DATA INTERFACE	Color Kinetics Data Enabler
CONTROL	Color Kinetics full line of controllers including Light System Manager or other DMX512 (RS485) sources

ELECTRICAL SPECIFICATIONS

POWER REQUIREMENT	100-240VAC, 50-60 Hz
POWER CONSUMPTION	30W at full output
POWER FACTOR	0.95 or greater at 120VAC

ENVIRONMENTAL SPECIFICATIONS

TEMPERATURE RANGE	-4°F to 122°F (-20°C to 50°C) based on testing of specific product
PROTECTION RATING	IP66

SOURCE LIFE

Color Kinetics illumination products utilize high brightness LEDs as the illumination source. LED manufacturers predict LED life of up to 100,000 hours MTBF (mean time between failure), the standard used by conventional lamp manufacturers to measure source life. However, like all basic light sources, LEDs also experience lumen depreciation over time. So while LEDs can emit light for an extremely long period of time, MTBF is not the only consideration in determining useful life. LED lumen depreciation is affected by numerous environmental conditions such as ambient temperature, humidity and ventilation. Lumen depreciation is also affected by means of control, thermal management, current levels, and a host of other electrical design considerations.

Color Kinetics systems are expertly engineered to optimize LED life when used under normal operating conditions [ambient temperature: -4°F to 104°F (-20°C to 40°C), humidity: 0-95% non-condensing humidity, adequate ventilation and air volume] and when operated using typical color-changing effects. Long-term operation outside of these ranges or conditions, or at the upper limits of these ranges or conditions, may subject the product to further degradation of the LED source life, or in extreme cases, failure of internal components. Source life information is based on LED manufacturers' data, as well as other third party testing.



FIXTURE ITEM# 123-00002-00 (White)
123-00002-01 (Black)
123-00002-02 (Aluminum)

BASE ITEM# 123-00003-00 (White)
123-00003-01 (Black)
123-00003-02 (Aluminum)

U.S. PATENTS 6,016,038, 6,150,774, 6,340,868, AND 6,788,011
FOREIGN PATENTS: EUROPE 1,016,062, AUSTRALIA 757000,
HONG KONG 1025416, AND CANADA 2,302,227
OTHER PATENTS PENDING

©2004 Color Kinetics Incorporated. All rights reserved.
Chromacore, Color Kinetics, the Color Kinetics Logo, ColorBlast,
ColorBlaze, ColorBurst, ColorPlay, ColorScape, iColor, iColor Cove,
iPlayer, QuickPlay, and Smartjuice are registered trademarks, and
Chromatic, ColorCast, Optibin, and Powercore are trademarks of
Color Kinetics Incorporated.

All other brand or product names are trademarks
or registered trademarks of their respective owners.

BRO141 Rev 00

Specifications subject to change without notice.

COLORCAST 14 CONDUIT

PHOTOMETRIC PERFORMANCE

Photometric data is based on test results from an independent testing lab.

SOURCE SPECIFICATIONS

Optics:	Tempered soft focus glass diffuser
Source:	18 LEDs (6 Red, 6 Green, 6 Blue)
Beam Angle:	110° (at 50% of peak illuminance)
Distribution:	Symmetric direct illumination
CCT:	Adjustable 1,000–10,000K
CRI:	Not measurable (CIE 13.3-1995)

GAMUT

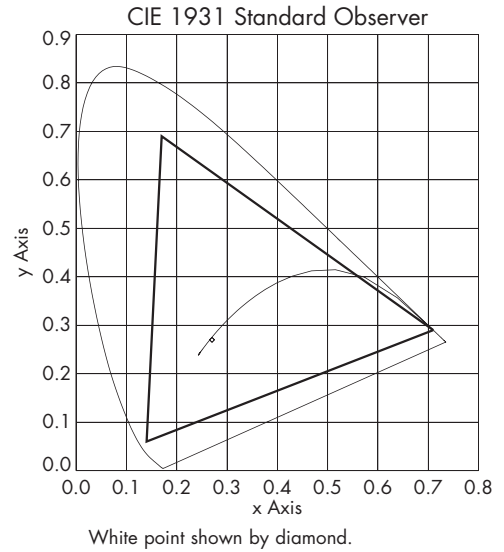

ILLUMINANCE DISTRIBUTION

1.8 19.4	4.1 44.1	6.7 72.1	6.9 74.3	4.6 49.5	2.2 23.7	1.0'/0.3m
2.8 30.1	5.3 57.0	7.8 84.0	8.1 87.2	5.5 59.2	2.7 29.1	
2.6 28.0	4.1 44.1	5.8 62.4	6.4 68.9	5.2 56.0	3.1 33.4	3.0'/1.0m
2.0 21.5	2.7 29.1	3.2 34.4	3.3 35.5	3.1 33.4	2.4 25.8	4.0'/1.2m
1.5 16.1	1.7 18.3	1.8 19.4	1.8 19.4	1.8 19.4	1.6 17.2	5.0'/1.5m
1.1 11.8	1.2 12.9	1.2 12.9	1.2 12.9	1.2 12.9	1.2 12.9	6.0'/2.0m
3.0'/1.0m		0'/0m		3.0'/1.0m		

Units: Footcandles (top)/Lux (bottom)
 Measured on: White
 Distance from surface: 2'/0.6m (from top of grid with light at a 60° angle off horizontal)
 Multipliers: 0.42 Red, 0.21 Green, 0.37 Blue

CANDLE POWER DISTRIBUTION

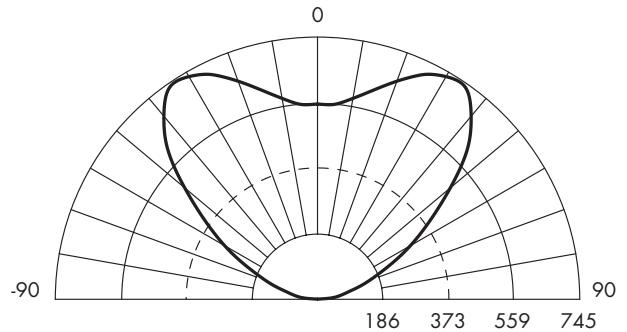

ILLUMINANCE

COLOR	3' 1m	6' 2m	9' 3m	15' 5m
WHITE	82.8 891.0	20.7 222.8	9.2 99.0	3.6 35.6
RED	34.8 374.2	8.7 93.6	3.9 41.6	1.4 15.0
GREEN	17.4 187.1	4.3 46.8	1.9 20.8	0.7 7.5
BLUE	30.6 329.7	7.7 82.4	3.4 36.6	1.2 13.2

Measured in Footcandles (top)/Lux (bottom) on axis.

LIGHT OUTPUT

COLOR	TOTAL OUTPUT (LUMENS)	POWER (WATTS)	EFFICACY (lm/W)
WHITE	213	28.0	7.6
RED	89.5	9.7	9.2
GREEN	44.7	10.7	4.2
BLUE	78.8	10.7	7.4

COLORCAST 14 CONDUIT

PHYSICAL DIMENSIONS

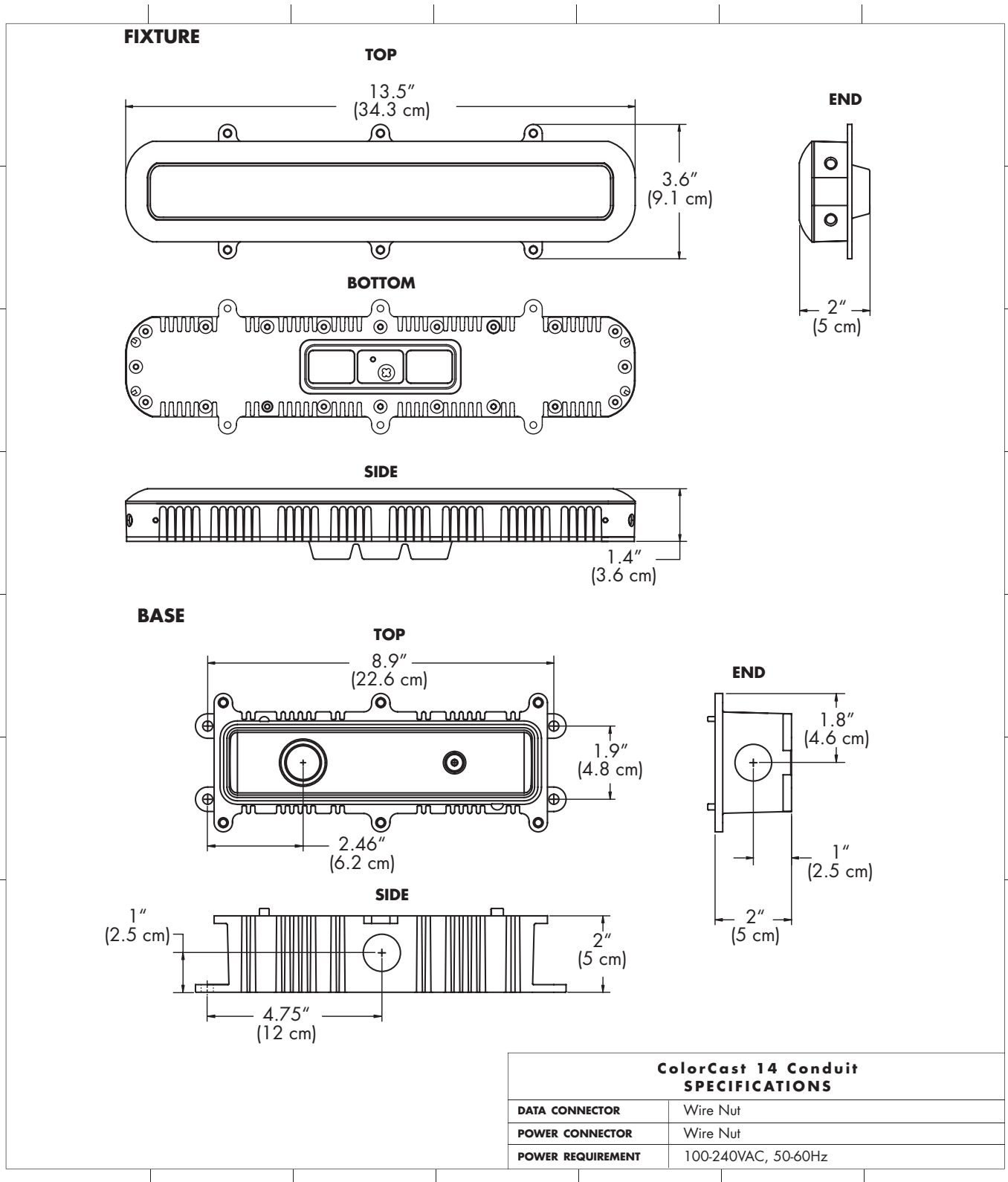

ColorCast 14 Conduit SPECIFICATIONS

DATA CONNECTOR	Wire Nut
POWER CONNECTOR	Wire Nut
POWER REQUIREMENT	100-240VAC, 50-60Hz

COLORCAST 14 CONDUIT

FUNCTIONAL FLOW DIAGRAM

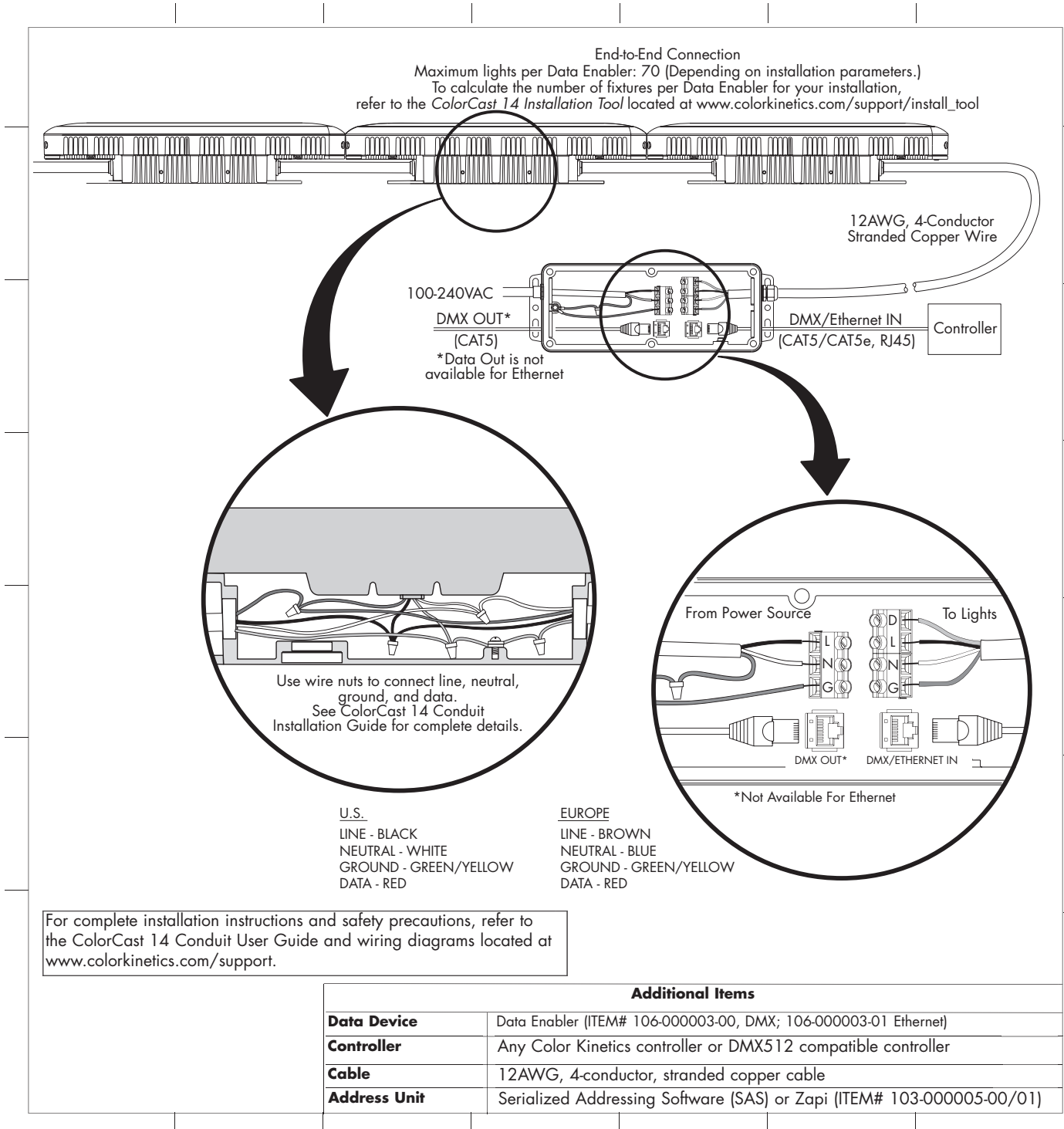

U.S. AND FOREIGN PATENTS AND PATENTS PENDING

COLOR CONSISTENCY

There are inherent variations in the fabrication processes of all semiconductor materials. For LEDs, this variance results in differences in the color and intensity of light output as well as electrical characteristics. Due to these differences, LED manufacturers sort production into "bins," but insuring the availability of a single bin is very difficult. To minimize this issue and achieve optimal color consistency in its products, Color Kinetics has developed and uses a proprietary technology called Optibin™. Optibin is an advanced production binning optimization process that minimizes the effects of LED variance for the best possible output uniformity in the final product. Color Kinetics Optibin technology gives the most consistent control of color and intensity from product to product.

COLOR KINETICS INCORPORATED • 10 MILK STREET, SUITE 1100 • BOSTON, MA 02108 • USA

TEL 888 FULL RGB • TEL 617 423 9999 • FAX 617 423 9998 • INFO@COLORKINETICS.COM • WWW.COLORKINETICS.COM